

F1 (Faston-Anschluss 4,75mm)

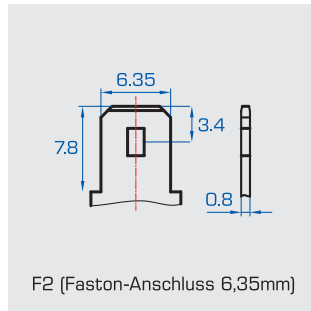

F2 (Faston-Anschluss 6,35mm)

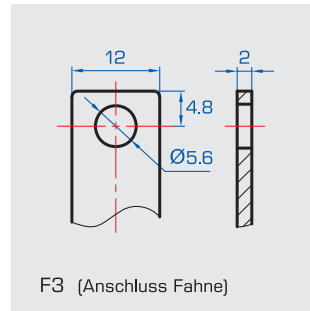

F3 (Anschluss Fahne)

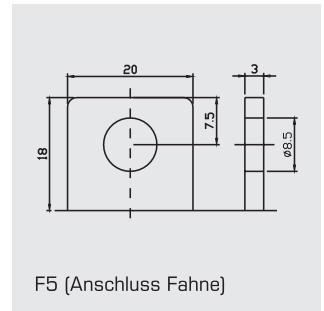

F5 (Anschluss Fahne)

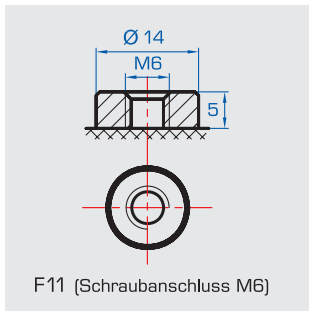

F11 (Schraubanschluss M6)

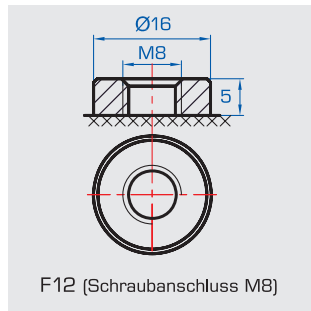

F12 (Schraubanschluss M8)

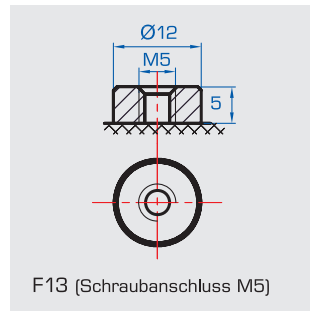

F13 (Schraubanschluss M5)

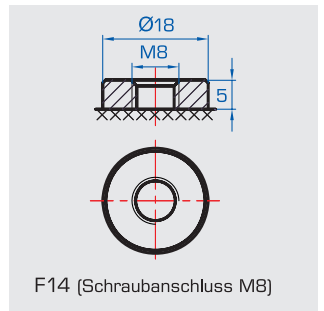

F14 (Schraubanschluss M8)

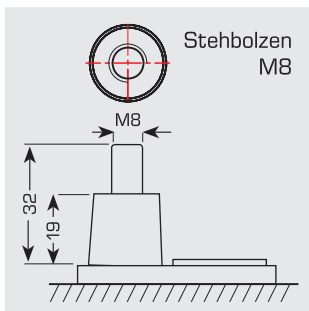

Stehbolzen
M8

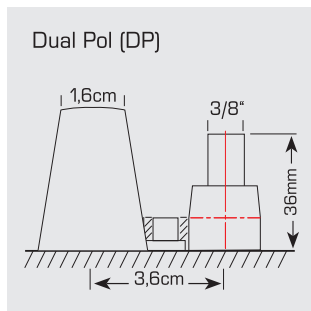

Dual Pol (DP)

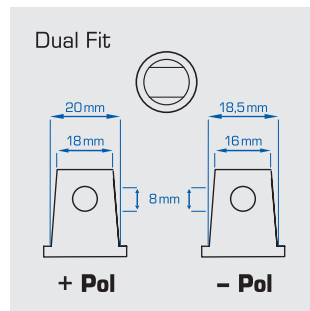

Dual Fit

+ Pol

- Pol

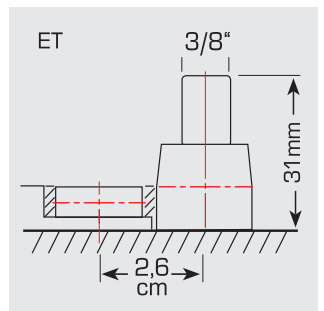

ET

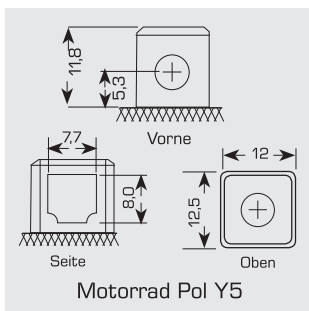

Motorrad Pol Y5

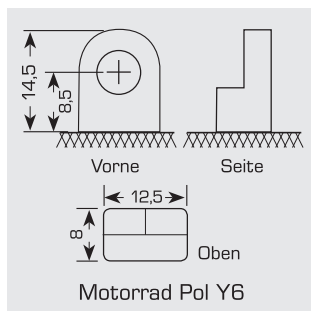

Motorrad Pol Y6

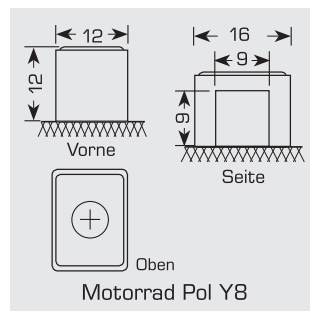

Motorrad Pol Y8

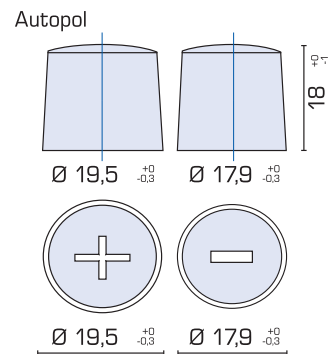

Autopol

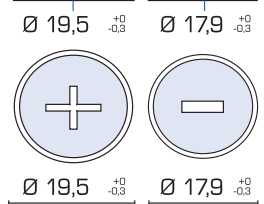

Schaltung

0

1

3

4

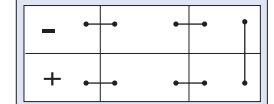
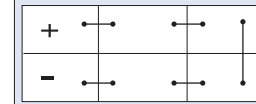
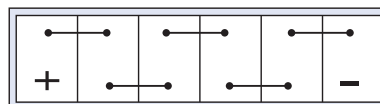
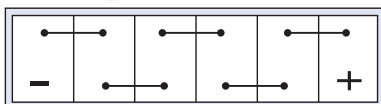

Bodenleiste B0

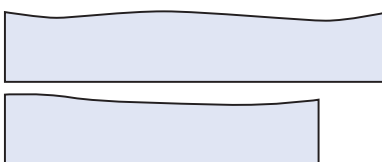

Bodenleiste B1

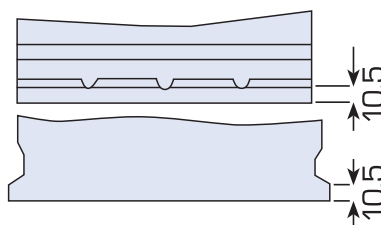

Bodenleiste B13

